

CL-Series

Pneumatic clamp



**Extra-light
products**

**550gr
WEIGHT**



Miniature light-weight series, enclosed toggle-locking mechanism, compact and light-duty for testing applications, welding and fixture checking.

CLAMPING

Technical features

Manual release button to open the linkage when air pressure is removed during setup.

Operating features

Operating pressure	from 2 to 5 bar / from 30 to 72,5 psi
Lubrication	all the devices are lubricated for life at the factory. Inline air lubrication isn't required

Functional charts

Size 25 mm

- Air consumption**

Air consumption for complete cycle (opening and closing)
REV. 00 - 17/06/2015

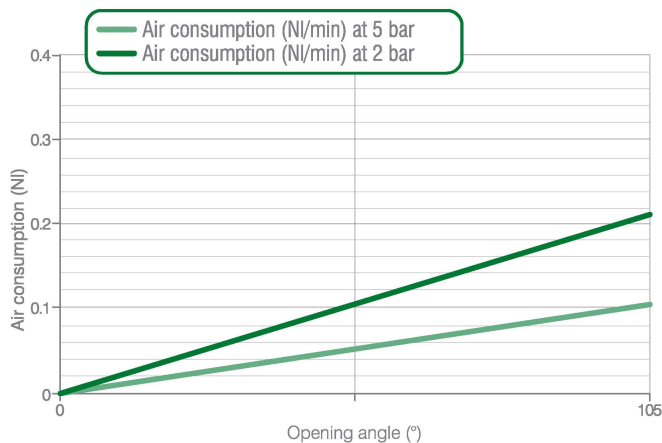

- Tooling weight chart**

5 bar operating pressure – 105° opening angle
REV. 00 - 18/11/2016

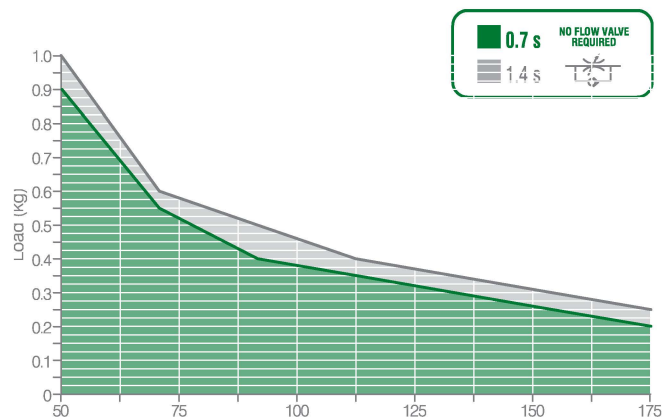

- Clamping moment (at 5 bar / 72.5 psi)**
25 N m / 18,43 lb-ft

- Holding moment**
50 N m / 36,87 lb-ft





The above data are meant for correct working conditions of the clamp with the same performance level during its life time. For applications which exceed the above data, please contact our sales representatives.

CL-Series / Ordering string

CL-Series

C L 25 E G 1 A 01

CLAMPING

C	VERSION	C = clamp
L	SERIES	L = light - Weight
25	SIZE	25 = Ø 25 mm
E	SENSOR	E = electronic sensor with M12 swivel connector - PNP A = electronic sensor with M12 swivel connector - NPN N = no sensor B = electronic sensor with M8 swivel connector - PNP
G	PORTS	G = G thread – BSPP
1	ARM MOUNT	1 =  2 =  3 =  4 = 
A	ARM MATERIAL	A = aluminum
01	CLAMP ARM TYPE	01 = wishbone, central, 0 mm offset 13 = H, 0 mm offset 04 = wishbone, central, 10 mm offset 14 = H, 10 mm offset

Please see the charts in the datasheets for arm position as well as for max. opening angle. NAAMS clamping arms to be ordered separately

CL25EG / Light - weight - pneumatic clamp - size 25 mm

WEIGHT 550 gr

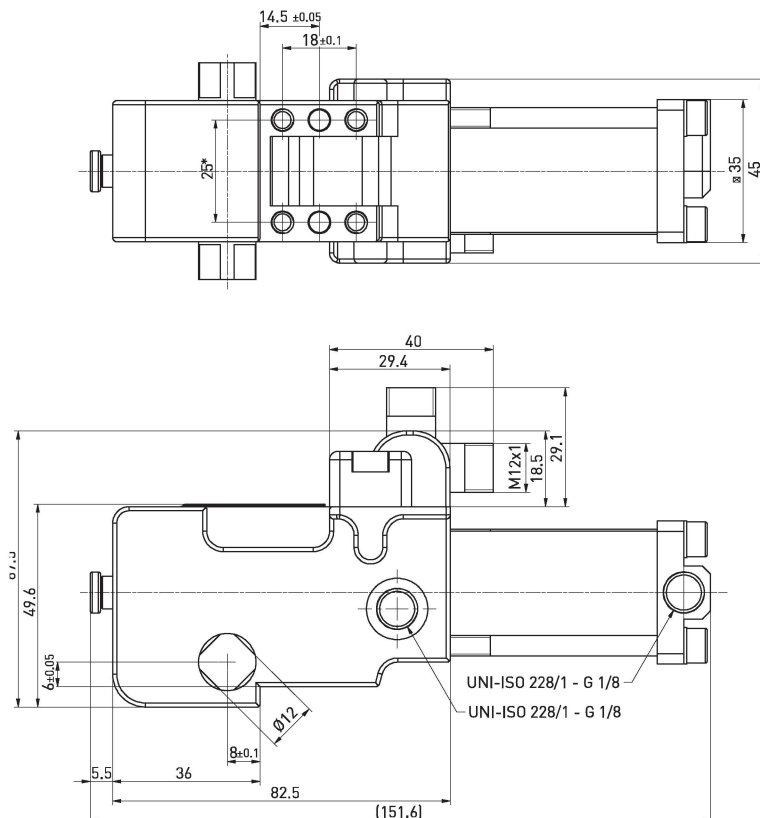

* DIMENSIONAL TOLERANCE FOR DOWEL HOLES: ±0.02
DIMENSIONAL TOLERANCE FOR THREADED HOLES: ±0.1

REV. 00 - 14/06/2021

Clamping arms / 12 mm shaft for clamps' size 25 mm

REV. 02 - 07/10/2015

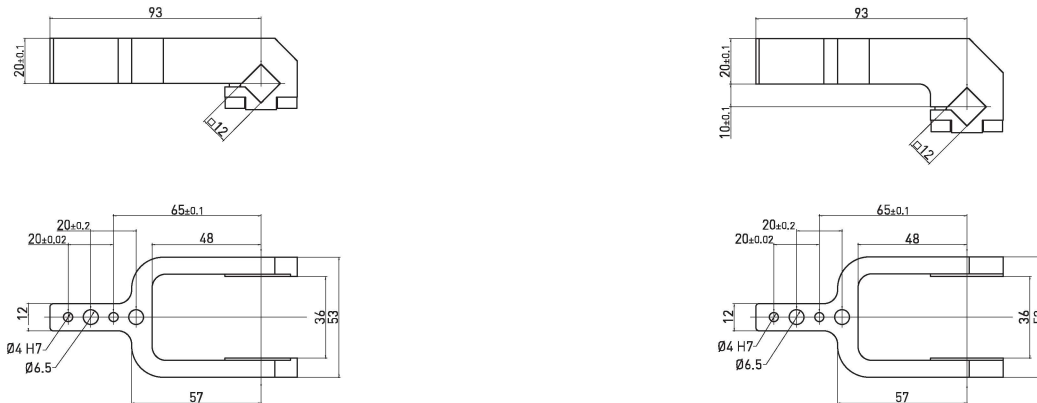

12 mm shaft – 0 mm offset

Part no.	Material	Version	Weight (kg)	Max op. angle pos. 1	Max op. angle pos. 2	Max op. angle pos. 3	Max op. angle pos. 4
B12012	Aluminum	Central	0.127	105°	105°	105°	N/A

Screws: M5x14 Tightening torque: 5 N m / 3.68 lb ft

12 mm shaft – 10 mm offset

Part no.	Material	Version	Weight (kg)	Max op. angle pos. 1	Max op. angle pos. 2	Max op. angle pos. 3	Max op. angle pos. 4
B12042	Aluminum	Central	0.135	105°	105°	N/A	N/A

Screws: M5x14 Tightening torque: 5 N m / 3.68 lb ft

Clamping arms / 12 mm shaft for clamps' size 25 mm and size 32 mm mm - Left & right clamping surfaces

REV. 00 - 12/04/2017

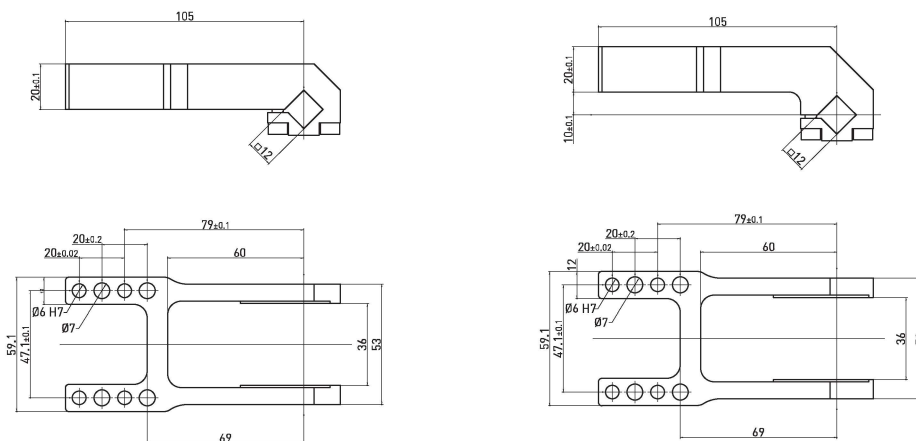

12 mm shaft – 0 mm offset

Part no.	Material	Version	Weight (kg)	Max op. angle pos. 1	Max op. angle pos. 2	Max op. angle pos. 3	Max op. angle pos. 4
B1213	Aluminum	H	0.163	105°	105°	N/A	N/A

Screws: M5x14 Tightening torque: 5 N m / 3.68 lb ft

12 mm shaft – 10 mm offset

Part no.	Material	Version	Weight (kg)	Max op. angle pos. 1	Max op. angle pos. 2	Max op. angle pos. 3	Max op. angle pos. 4
B1214	Aluminum	H	0.173	105°	105°	N/A	N/A

Screws: M5x14 Tightening torque: 5 N m / 3.68 lb ft